

PROJECT PROFILE ON ROASTED RICE FLAKES



INTRODUCTION

Generally the beaten rice is a popular food for all kinds of human living in India. Most people used this as a raw food in ancient times which is very easy to produce and prepare at home. Now the people are making different kinds of recipes with this by adding sweetness or spices. This is rich in fiber and carbohydrate and can be consumed even by those suffering from diabetes, high blood pressure etc. Now the medical journals are also encouraging the same. Another point to be remembered is that paddy is available in plenty in Odisha and hence the raw material has no shortage.

PRODUCT

CFTRI Mysore has introduced new methods to evolve the roasted flakes with different spices and sweetness. This can be directly used as a snack or light food. This can easily attract both small children and elders. Also one of the specialties is the easiness with which the product can be prepared though it consumes a little time.

MARKET POTENTIAL

This product in the market is relatively new one. Hence it has tremendous scope. A good quality product in attractive pack will give a boost in marketing the product. The main scenario in rice flakes is that it is pure in nature and adding spices or sweets will not contaminate it in any way.

TECHNICAL ASPECTS

The Process

The paddy is cleaned and stones are removed. It is soaked in water and boiled in a boiler. When it is lowered its temperature is reduced a little and is pounded or pressed mechanically to form flakes. It is sieved and roasted by adding the required flavors. This product is packed and labeled in different weights.

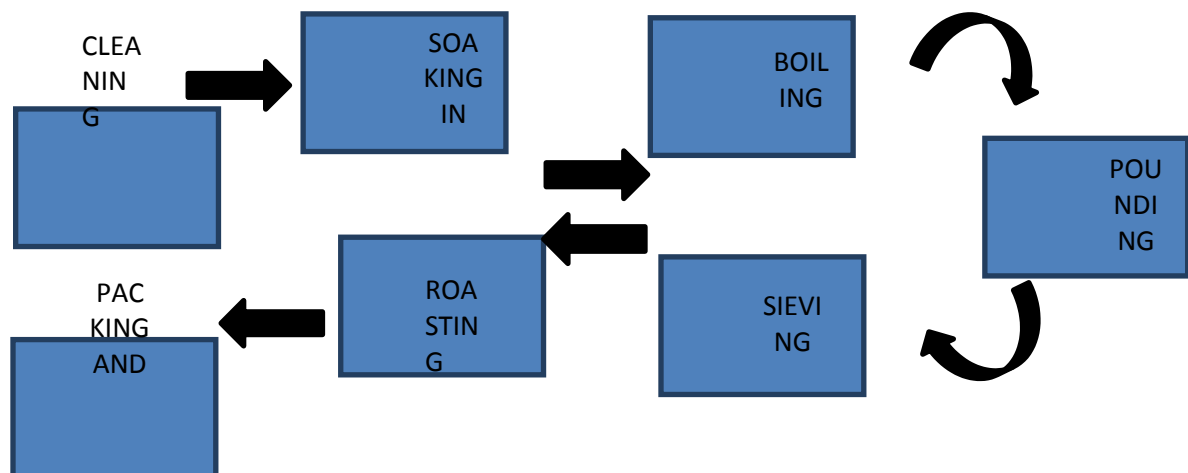

Pollution Control

This industry does not create any kind of pollution and as such there is no need of any preventive measures.

FINANCIAL ASPECTS

Fixed Capital

Land and building

It is estimated that a land of 250 sqm is required with 125sqm with build up area. Cost of land in rural area is calculated as Rs1,25,000/- and the cost of construction is taken as Rs3,25,000/-

Plant and machinery

It is suggested to install a unit with annual production capacity of 250MT based on 300 working days and 1 shift per day.

No	ITEM	QUANTITY	PRICE(IN LAKHS)
1	Avil mill	2	1.50
2	Roaster	2	1.00
3	Husk fired Furnace	1	0.25
4	Paddy soaking tanks	4	0.60
5	Sieves	4	0.25
6	Sealing machines	1	0.25
		TOTAL	3.85

Furniture and fixing

A provision of Rs 40,000/- is provided for the working tables furniture and fixtures storage facilities.

Utilities

Power requirement shall be 15 hp and daily water consumption is Rs750 for 800 liters

Manpower requirement

Particulars		Monthly salary(Rs)	Total Monthly salary(Rs)
Skilled workers	2	7500	15000
Semi-skilled Workers	2	5000	10000
Helpers	2	5000	10000
Sales man	1	6000	6000
		TOTAL	41000

Details of project cost

A) Land and building

Particulars	Area	Cost(Rs)
Land	250SqM	125000
Building	125SqM	325000
	TOTAL	450000

B) Plant and machinery

A total cost of Rs3.85 Lakhs is calculated in this head.

C) Miscellaneous assets

A provision of Rs 40,000/- is provided to this project

D) Preliminary and preoperative expenses

This include some charges like registration, trial run expenses, interest during implementation etc. and are covered with a provision of Rs 50,000/-

E) Working capital requirement (with a capacity utilization of 60%)

Particulars	Period	Margin	Promoters	Bank	Total(Lakhs)
Stock of Materials	1 Month	30%	0.30	0.80	1.10
Stock of Finished Goods	½ months	25%	0.14	0.41	0.55
Receivables	1 Month	25%	0.26	1.39	1.65
Working Expenses	1 month	100%	0.20		0.20
		Total	0.90	2.60	3.50

Cost of project

Item	Amount(Lakhs)
Land and Building	4.50
Machinery	3.85
Miscellaneous assets	0.40
Preliminary & Preoperative Expenses	0.50
Contingencies @10% on fixed assets	0.84
Working Capital	3.50
	13.59

Means of Finance

Promoters contribution		4.07
Loan from bank	Term loan 6.92 Working capital 2.6	9.52
Total		13.59

Assumptions

a) **Utilities:** the annual expenditure towards power and water is estimated to be Rs 60000/-

b) **Selling expenses:** Rice flakes will be sold through retailers. For this commission and transportation charges will be there. Hence a provision @ 12.5% is provided.

c) **Interest** on term loan is calculated as 12% per annum assuming a repayment period of 4years. Interest on working capital is taken as 14% per annum.

d) **Depreciation.** It is calculated assuming @10% on building and @20% on plant and machinery

Raw material required per annum

Product	Quantity(MT)	Rate/ price	Value(In Lakhs)
Paddy	250	8900	22.25
Spices	25	4000	1.0
			23.25

Sales Revenue at 100%

Product	Quantity	Selling price	Sales(In Lakhs)
Roasted flakes	200	12000	24.00
Rice Bran	25	2000	1.0
			25.0

Calculation of profit

No	Particulars	Year1	Year2	Year3	Year4
A	Installed capacity	250MT			
	Capacity utilization	60%	70%	80%	100%
	Sales realization	24.5	31.85	34	38.25

B	Cost of production	Year 1	Year 2	Year 3	Year 4
	Raw materials	13.95	16.28	18.60	20.93
	Utilities	0.36	0.42	0.42	0.54
	Salaries	2.88	2.88	2.88	3.17
	Stores & Spares	0.20	0.20	0.20	0.20
	Repairs and Maintenance	0.30	0.30	0.30	0.30
	Selling expenses	1.91	1.99	1.99	1.99
	Administrative Expenses	0.30	0.30	0.30	0.30
	Total	19.9	22.37	25.48	28.76

C	Profit before Interest and Taxation	4.6	9.48	8.52	9.49
	Interest on Term loan	0.83	0.83	0.63	0.43
	Interest on working capital	0.36	0.36	0.36	0.36
	Depreciation (0.32+.77)	1.09	1.09	1.09	1.09
	Profit before tax	2.32	7.20	7.43	8.40
	Income tax @10%	0.23	2.28	2.08	2.52
	Profit after Tax	2.09	5.04	5.2	5.88
	Cash accruals	3.18	6.13	6.29	6.97

Break Even Analysis

No	Particulars	Amount(Lakhs)	
A	Sales		25.0
B	Variable cost		
	Raw materials	13.95	
	Utilities (60%)	0.22	
	Salaries (60%)	1.73	
	Stores & Spares	0.2	
	Selling expenses(60%)	1.15	
	Admn.expenses(50%)	0.15	
	Interest on working Capital	0.36	
			17.76
C	Contribution		

			7.24
D	Fixed Cost		
	Depreciation	1.09	
	Utilities	0.14	
	Salaries	1.15	
	Selling expenses	0.76	
	Administrative expenses	0.15	
			3.29
E	Break-even point (D/C)		45.44 %

Return on investment

Profit after tax/investment
 $= 2.09 / 13.59 * 100$
=15.37

SOME SUPPLIERS OF MACHINERIES

1) Indopol food processing industry pvt. Ltd., Faridabad 121003
Ph 2276161

2) SP Engg.works, Fazal Gunj, Kanpur